

Modulo Formativo Frontale

“Mobilità ciclistica in ambito urbano”

La ciclabilità: ritorno al futuro!

Il “veicolo perfetto”, per l’innovazione e la crescita di città e territori

Linea di intervento 7 – Sviluppo di Modelli e Strumenti per la Gestione della Mobilità Urbana Sostenibile



CReIAMO PA

Per un cambiamento sostenibile



CReIAMO PA
Per un cambiamento sostenibile

Federico Del Prete



Federico Del Prete



MINISTERO DELL'AMBIENTE
E DELLA TUTELA DEL TERRITORIO E DEL MARE

CRReIAMO PA

Per un cambiamento sostenibile



Federico Del Prete



Federico Del Prete

legambici



LEGAMBIENTE



CReIAMO PA

Per un cambiamento sostenibile

L'ABI CI

2° Rapporto sull'economia della bicicletta in Italia 2018



In collaborazione con



GRAB+



CReIAMO PA

Per un cambiamento sostenibile



UNIONCAMERE



ISNART



legambici



LEGAMBIENTE



1° Rapporto Isnart – Legambiente

CICLOTURISMO E CICLOTURISTI IN ITALIA

Bike Summit 2019



CReIAMO PA

Per un cambiamento sostenibile



CReIAMO PA

Per un cambiamento sostenibile

77 milioni di presenze (2018),
8,4% del movimento turistico in
Italia, **+41%** tra 2013 e 2018

Il **PIB** (Prodotto Interno Bici)
complessivo è (già) di ca.
€ 12 Mld./anno

6,7 milioni di
persone in bicicletta
producono un valore
di **€ 7,6**
Mld./anno



ISNART



UNIONCAMERE



LEGAMBIENTE



legambici



AMODO
Associazione Nazionale
Amatori di Mountain Bike



velo
love

GRAB+



CReIAMO PA

Per un cambiamento sostenibile

ciclabilità



CREIAMO PA

Per un cambiamento sostenibile

sostenibilità

sostenibilità

sostenibilità

sostenibilità

sostenibilità

sostenibilità



CReIAMO PA

Per un cambiamento sostenibile



CReIAMO PA

Per un cambiamento sostenibile

153. La qualità della vita nelle città è legata in larga parte ai trasporti, che sono spesso causa di grandi sofferenze per gli abitanti. Nelle città circolano molte automobili utilizzate da una o due persone, per cui il traffico diventa intenso, si alza il livello d'inquinamento, si consumano enormi quantità di energia non rinnovabile e diventa necessaria la costruzione di più strade e parcheggi, che danneggiano il tessuto urbano.



LETTERA ENCICLICA

LAUDATO SI'

DEL SANTO PADRE

FRANCESCO

SULLA CURA DELLA CASA COMUNE

MAGAZINE THE CITIES ISSUE

To build the cities of the future, we must get out of our cars

Remaking healthy urban areas means repairing damage done to communities once blown apart to serve the automobile.

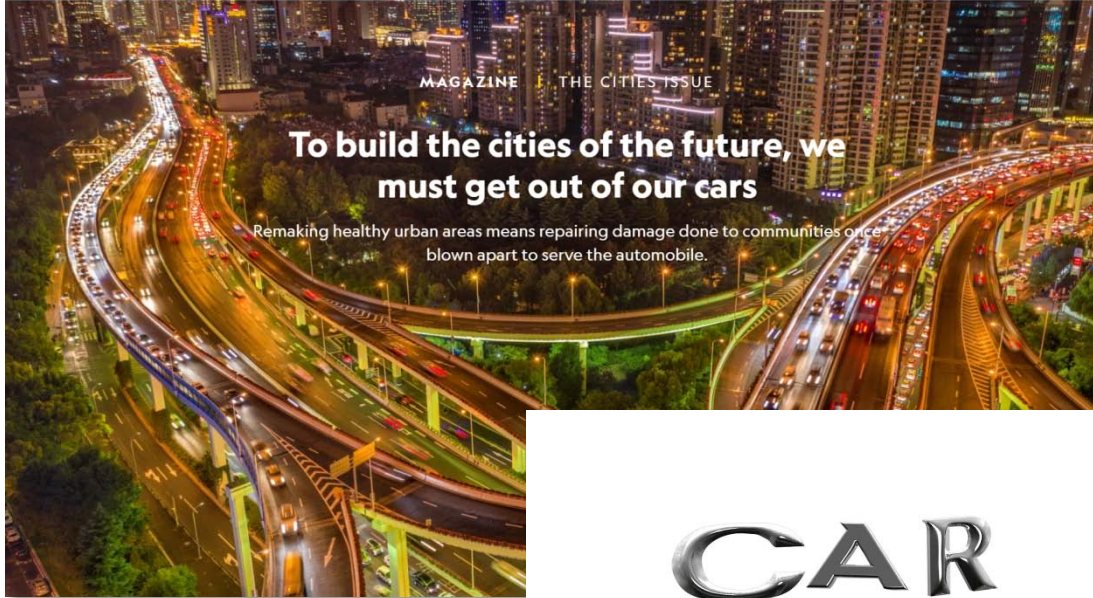

CAR
PROBLEMS

March 4, 2019

PEAK CAR

SPECIAL REPORT

We still drive 1.3 billion automobiles. But not for long. The mobility revolution is almost here.

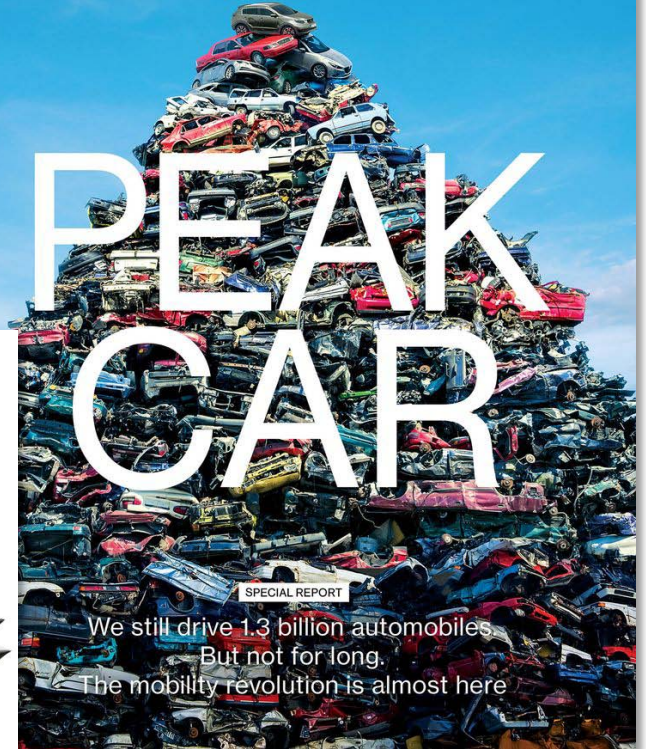



CReIAMO PA

Per un cambiamento sostenibile





CReIAMO PA

Per un cambiamento sostenibile

JOHN CARPENTER'S

CHRISTINE

CHARLTON HESTON'S PULP FICTION, JACKSON LUNDGREN'S SPOOKY HOGS, JOHN BOYER'S AND SACHMEL'S BLOODHOUND PHOENIX "CHRISTINE"

JOHN CARPENTER AND HESTON'S PULP FICTION, JACKSON LUNDGREN'S SPOOKY HOGS, JOHN BOYER'S AND SACHMEL'S BLOODHOUND PHOENIX

JOHN CARPENTER AND HESTON'S PULP FICTION, JACKSON LUNDGREN'S SPOOKY HOGS, JOHN BOYER'S AND SACHMEL'S BLOODHOUND PHOENIX

© 1982 COLUMBIA PICTURES INC. ALL RIGHTS RESERVED. "CHRISTINE" IS A TRADEMARK OF COLUMBIA PICTURES INC.



CREIAMO PA

Per un cambiamento sostenibile

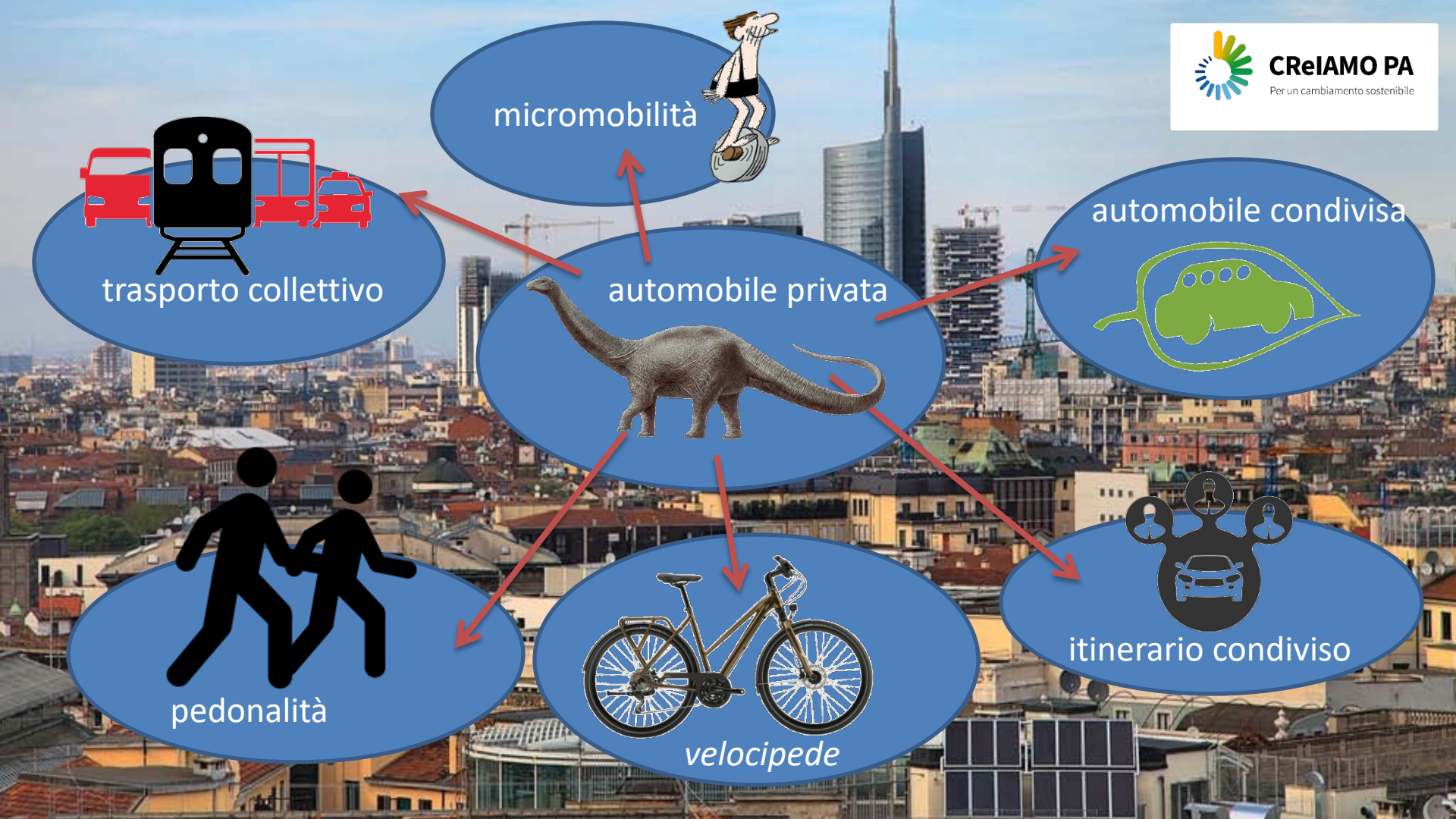
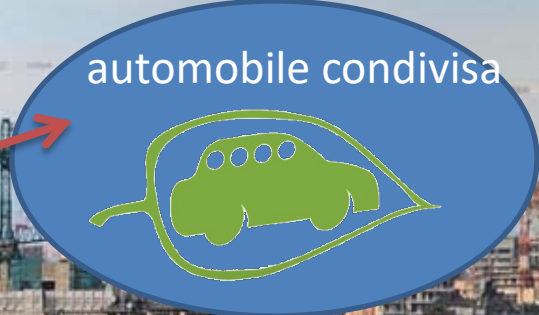
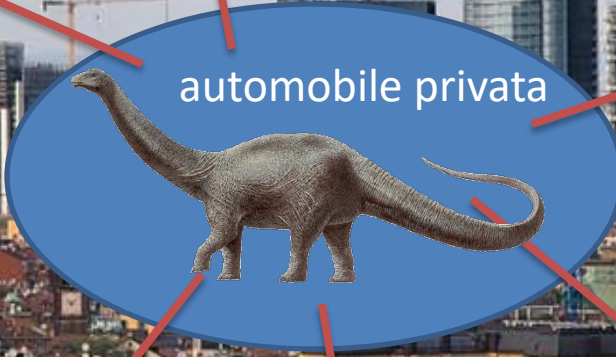



1927



1925



CReIAMO PA

Per un cambiamento sostenibile



CReIAMO PA

Per un cambiamento sostenibile



CRiAMO PA

Per un cambiamento sostenibile



CReIAMO PA

Per un cambiamento sostenibile





CReIAMO PA

Per un cambiamento sostenibile



11 aprile 1815





CREIAMO PA
Per un cambiamento sostenibile



1816



Karl Drais

1785-1851

(Karl Friedrich Christian
Ludwig
Freiherr
Drais von Sauerbronn)



CREIAMO PA

Per un cambiamento sostenibile

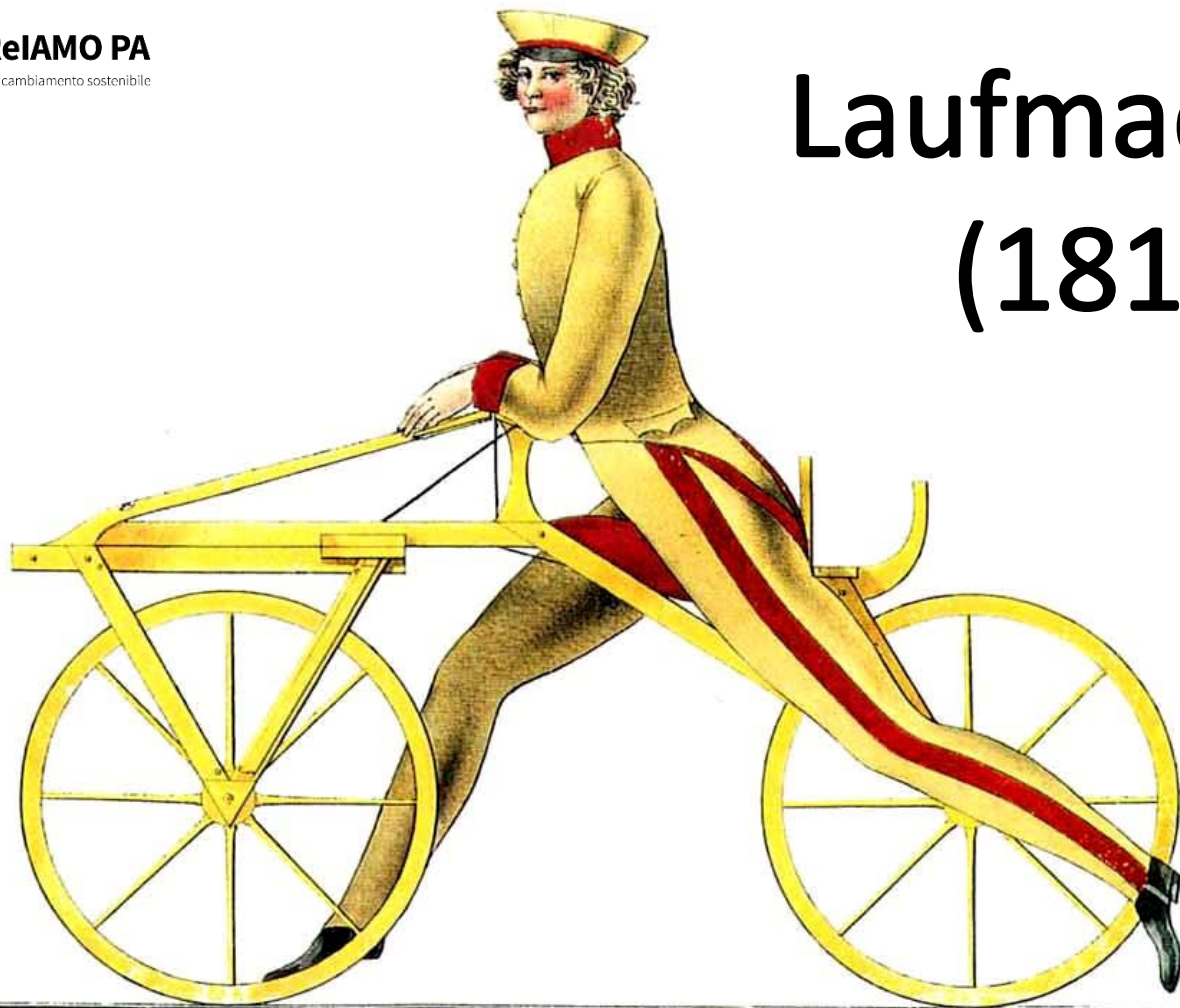

Laufmaschine (1817)





CREIAMO PA

Per un cambiamento sostenibile





CREIAMO PA

Per un cambiamento sostenibile



Hobbies or Attitude is every Thing Pub. April 17 1879 by J. T. Egg 111 Chesapeake
Dedicated with permission to all Bandy Horse men

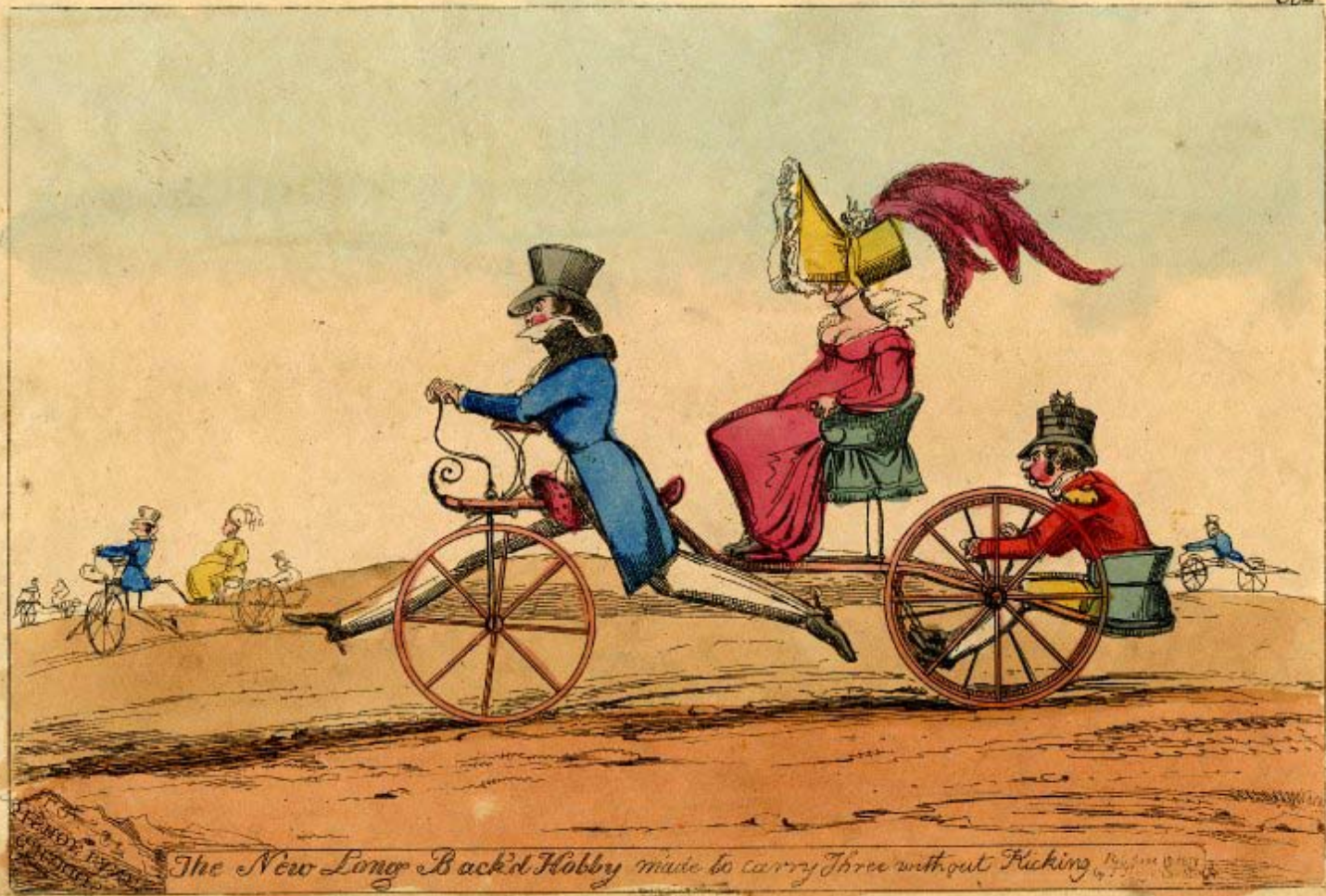

The New Long Back'd Hobby made to carry Three without Kicking



CReIAMO PA

Per un cambiamento sostenibile





CReIAMO PA

Per un cambiamento sostenibile

Mannheim

Mannheim - Schwetzingen

Karl Drais

12 giugno 1817

7 Km. (!)

A/R <1h (!!)

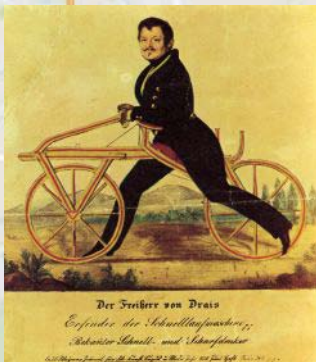

14 Km/h (!!!)

Schwetzingen



CREIAMO PA
Per un cambiamento sostenibile

60 volte meno energia di
un'automobile

5 volte meno energia di camminare

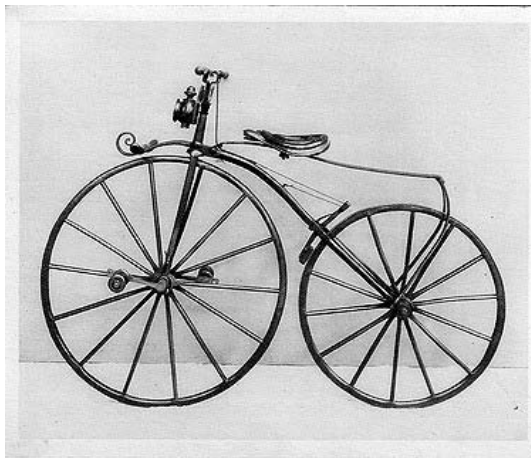

ca. 1860



ca. 1890



CREIAMO PA
Per un cambiamento sostenibile

Bicycles



CREIAMO PA

Per un cambiamento sostenibile

SEARS, ROEBUCK and CO. Chicago

1908-



CReIAMO PA

Per un cambiamento sostenibile



CReIAMO PA

Per un cambiamento sostenibile

1914





1914

1925



CREIAMO PA

Per un cambiamento sostenibile

A Traffic Problem—Jay Walking

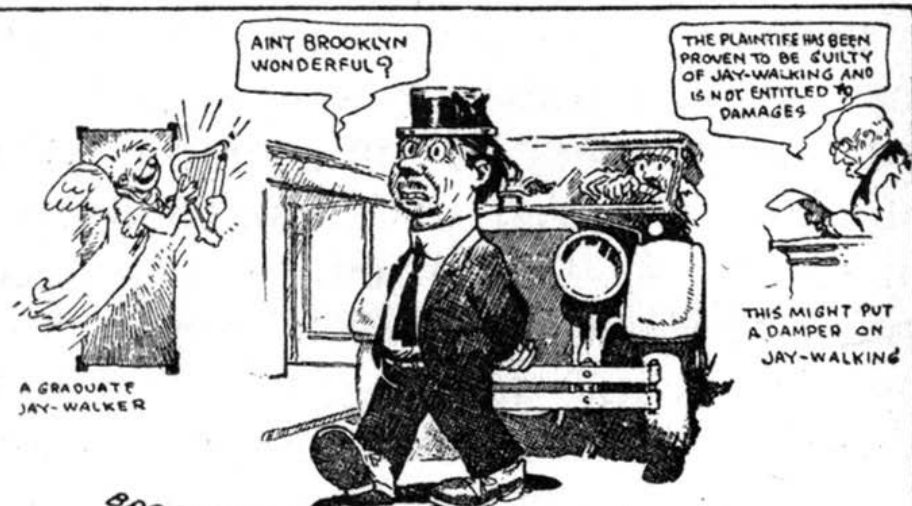

A GRADUATE JAY-WALKER

THIS MIGHT PUT A DAMPER ON JAY-WALKING

BROOKLYN STREETS

DON'T BE A JAY-WALKER

WONDER IF THIS THING IS LOADED?



JAY-WALKING IS FAR MORE DANGEROUS



UNIFORM FOR JAY-WALKERS



TIE A COWBELL ON THE JAY-WALKERS



THE JAY-WALKERS' CLUB HOUSE

SMITHSONIAN

DON'T JAY WALK



 **CREIAMO PA**
Per un cambiamento sostenibile

WATCH YOUR STEP



CReIAMO PA

Per un cambiamento sostenibile





CREIAMO PA

Per un cambiamento sostenibile



Caratteristiche tecniche:

PESO
solo 15,8 kg

PIEGATA
74,9 x 58,4 x 30,5 cm

NON PIEGATA
134,6 cm

COLORI
BLU o BIANCO smaltati

Technical characteristics:

WEIGHT
only 35 lbs.

FOLDED
29 1/2 x 23 x 12 inches

UNFOLDED
53 inches

COLOR:
BLUE or WHITE enamelled

1964: "Bicicletta pieghevole per facilitare il trasporto su automobile"



CREIAMO PA
Per un cambiamento sostenibile

YOU'VE READ ABOUT IT... HEARD ABOUT IT... AND HERE IT IS!

- RESPONSIVE
 - EASY TO PEDAL
 - EASY TO RIDE
 - EASY TO BALANCE
- Easy to Sell!*

Schwinn

EXCITING
NEW RIDING
THRILL!

NEW
1963 1/2



STING-RAY

An eye-stopping new look and a revolutionary new design that puts more fun in cycling. Unbelievable maneuverability based on a unique short turning radius. 20" cantilever frame combined with special equipment to form an unusual "full-size" bicycle.

*SUGGESTED ZONE 1 RETAIL

SCHWINN QUALITY FEATURES

- Butterfly style handlebars
- Forged steel fork
- Schwinn front hub
- Schwinn tubular rims
- Bendix coaster brake
- Solo-Polo braced saddle
- 20" x 2 1/2" studded rear tire
- 20" x 1 1/2" Nylon front tire

ARNOLD, *Schwinn* & COMPANY • CHICAGO 39, ILL.



They'll never forget a
COLUMBIA
Christmas!

Columbia
SUPER-EQUIPPED
FIVE STAR SUPERB MOTOBIKE



CReIAMO PA

Per un cambiamento sostenibile



CReIAMO PA

Per un cambiamento sostenibile



24
HOUR

FITNESS

HEALTHY RETURN
ON YOUR SECURITY
INVESTMENT
BY
REINVESTING IN
YOURSELF

WEAVING THE
ART OF
LIVING

FITNESS

24
HOUR

POINT LO...
HANDICAP...
TO UPPER...
LOCATED...
24 HOUR...



CRiAMO PA

Per un cambiamento sostenibile



Amsterdam 1960 - 1970



1973



CREIAMO PA

Per un cambiamento sostenibile





CREIAMO PA

Per un cambiamento sostenibile



I ❤️ S.U.V.!!!



Freiburg

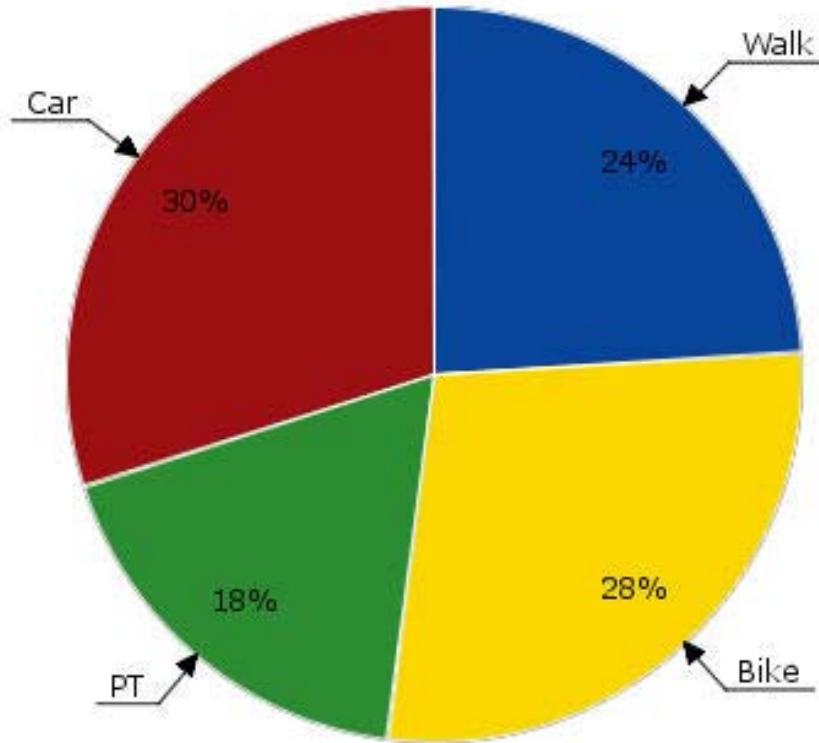

Source:

City of Freiburg

Survey method:

Representative household survey

Year:

2001

Population:

221.924



CReIAMO PA

Per un cambiamento sostenibile

The City of Cyclists

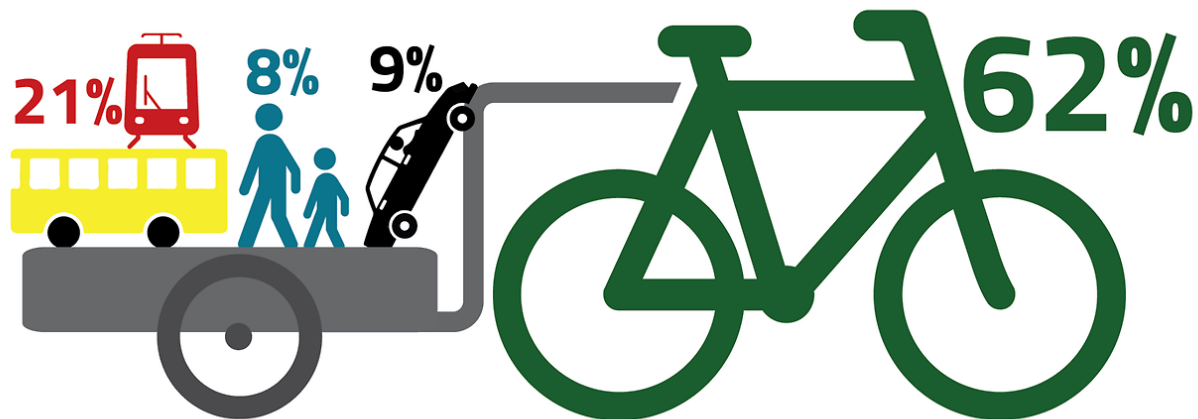

How citizens of Copenhagen get to work or education each day

perché



CREIAMO PA

Per un cambiamento sostenibile

PROTECTED BIKE LANES MEAN BUSINESS



How 21st Century
Transportation
Networks Help
New Urban
Economies Boom

A report from PeopleForBikes and
Alliance for Biking & Walking



De fiets
als motor
van de
economie

klant

klant

klant

klant

klant

klant

klant

klant

klant

€€€, €€, €€!

individual savings

- no fuel
- no insurance
- no taxes
- no fix costs
- low maintenance costs
- no parking costs

4.800 €
annual cost of the ownership
of a car in Italy*



THIS ONE RUNS ON FAT AND SAVES YOU MONEY



THIS ONE RUNS ON MONEY AND MAKES YOU FAT

* source: Confcommercio (2012)

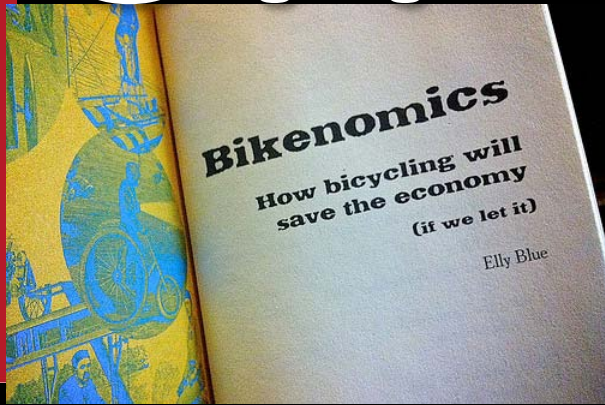



De fiets als motor van de economie

klant

klant

klant

klant

klant

klant

klant

klant

klant

klant

klant?

cliente!



CReIAMO PA

Per un cambiamento sostenibile



klant!

Nomentana, la ciclabile che cancella 160 posti auto: proteste dei residenti

ROMA > CRONACA

Domenica 28 Gennaio 2018 di Camilla Mozzetti



Il progetto è stato annunciato e il cantiere è partito. Le strisce gialle

danr

accra

Via Mantova, nuova ciclabile: subito proteste e polemiche

Le critiche corrono sui social col cantiere iniziato da meno di una settimana: poca sicurezza e meno parcheggi. L'assessora Manfredini: 'Giudicate quando sarà finita'

nuov



Pia a via Val d'Aosta-Valdarno) che però già da adesso malumori tra i residenti. «Dove andremo a parcheggiare delle tante residenti, Letizia Magistri, che ha già inviato sindaco Raggi. Il progetto infatti prevede la cancellazione riservata ai cittadini che vivono sulla Nomentana.



"LA PISTA CICLABILE NON CI FA PIU' VENDERE". LA PROTESTA DEI COMMERCianti DI ROMA TUSCOLANA

7 dicembre 2018 gn, Tutti gli Articoli 1,181 Visualizzazioni



quasi finita in rissa la riunione esterna dell'amministrazione capitolina che si è tenuta oggi a Roma, in via Tuscolana, alla quale hanno partecipato tutti i commercianti della zona. Il motivo della contesa è la nuova pista ciclabile in costruzione lungo una delle zone più



Mi piace 401



GAZZETTA DI PARMA

IL MIO COMUNE EVENTI FILM RISTORANTI SPORT IL PARMA GAZZAREPORTER ELEZIONI 2019

sei in » Gweb+

VIABILITÀ

Pista ciclabile e proteste

Video

RUSSIA
Ubrisco te

SEGUICI SU



LA STAMPA BIELLA

Avanza in centro la nuova pista ciclabile, ma sui social fioccano le proteste dei cittadini



CREIAMO PA

Per un cambiamento sostenibile



Italia:

625

/1000



Eurostat, 2017



CReIAMO PA

Per un cambiamento sostenibile



CReIAMO PA

Per un cambiamento sostenibile

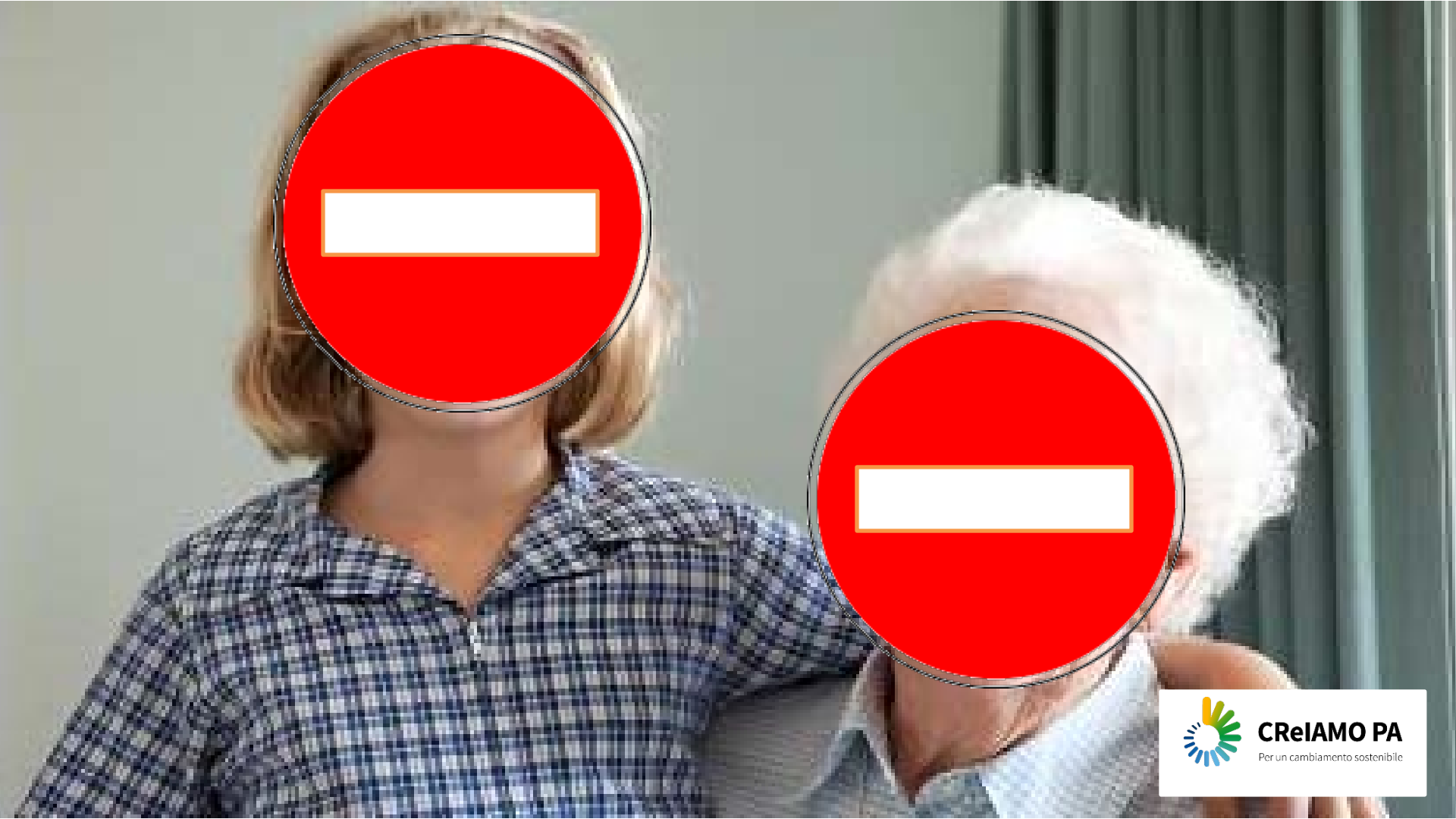

CReIAMO PA

Per un cambiamento sostenibile



CREIAMO PA

Per un cambiamento sostenibile

8

80



CReIAMO PA

Per un cambiamento sostenibile



CREIAMO PA

Per un cambiamento sostenibile



CRiAMO PA
Per un cambiamento sostenibile



CReIAMO PA

Per un cambiamento sostenibile



CReIAMO PA

Per un cambiamento sostenibile

Febbraio 2012



Ottobre 2015



Marzo 2016



Luglio 2016



Dicembre 2017



federico.del.prete
Milan, Italy



federico.del.prete Ready for a new
#day of #bikelife
#cyclinglife
#bikeyourlife
#urbancycling
#urban
#breakfast
#milano
#steelisreal



62 sett.



Piace a paola.cannucciari e altri 38

27 FEBBRAIO 2018

Aggiungi un commento...

Pubblica

10' di pausa?



CReIAMO PA

Per un cambiamento sostenibile





CReIAMO PA

Per un cambiamento sostenibile





CReIAMO PA

Per un cambiamento sostenibile

ciclabilità

BERMUDA

FLORIDA

pedonalità

**trasporto
collettivo**

PUERTO
RICO

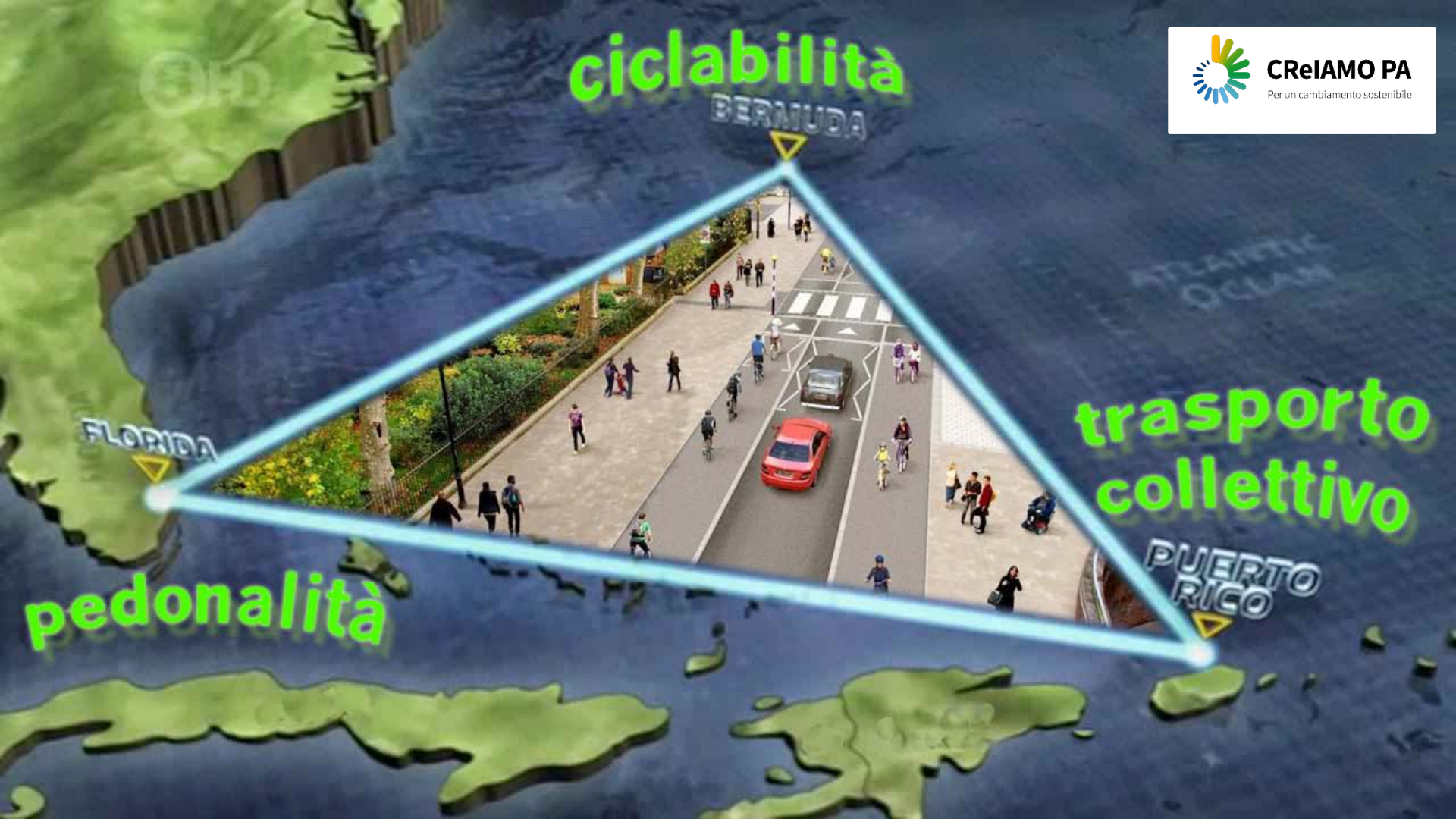



CReiAMO PA

Per un cambiamento sostenibile





CRiAMO PA
Per un cambiamento sostenibile



CReIAMO PA

Per un cambiamento sostenibile

come fare





CReIAMO PA

Per un cambiamento sostenibile

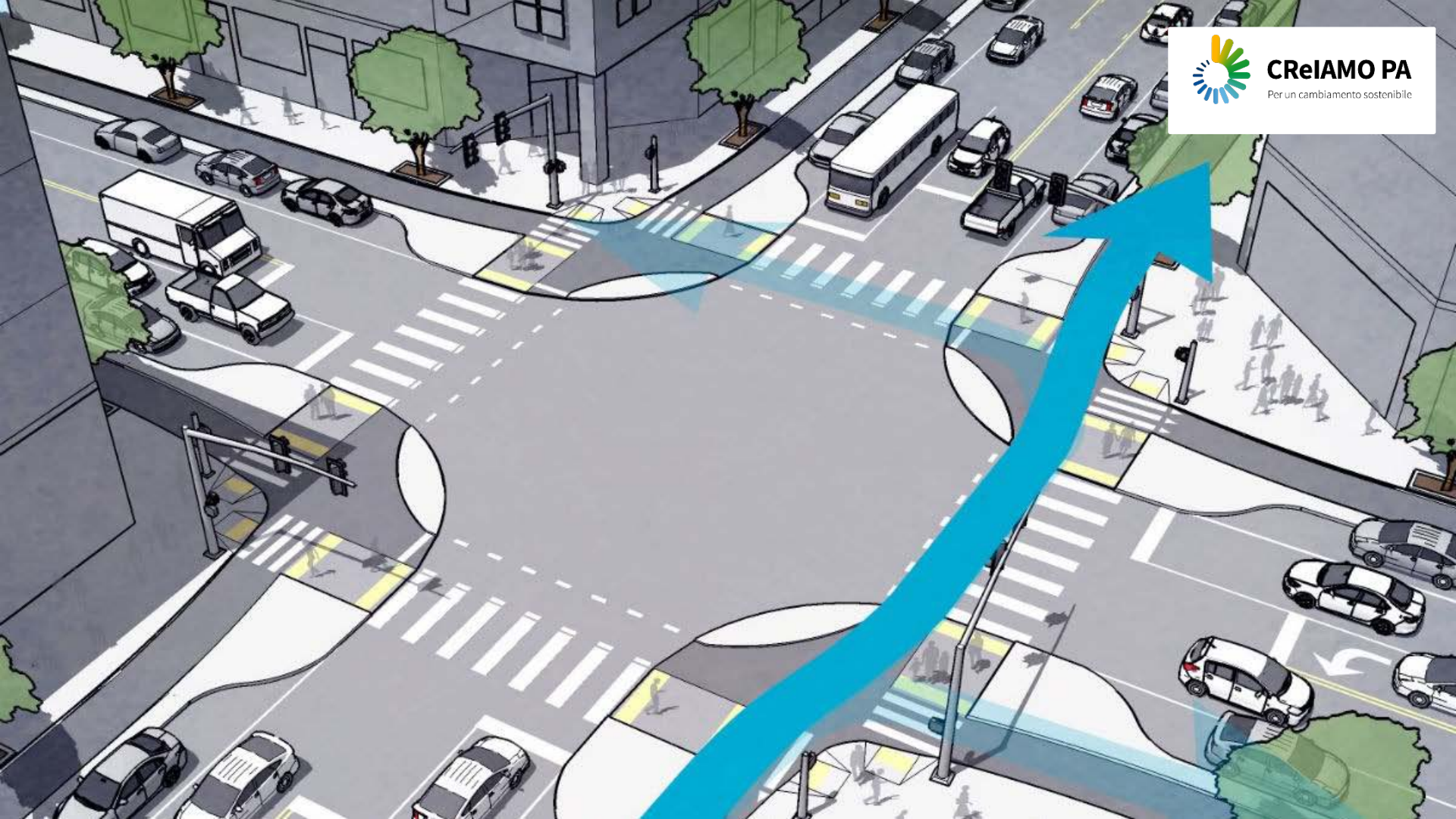





legamb**ici**

@

ascolto

©

consulenza

f

formazione

π

progettazione



CReIAMO PA

Per un cambiamento sostenibile

A Scuola di Bicipolitana: prima edizione Pesaro, 11-13 ottobre, 2018



- La *Bicipolitana* di Pesaro (ca. 94K ab., 126 Km², 7,4K ab./ Km²)
- Rete organica, connessa ed estesa (14 “linee”, ca. 90 Km.)
 - Assonanza con TPL: la bici è trasporto pubblico



- Amministrazioni locali, professionisti (Architetti, Ingegneri, Giornalisti)
- Ascolto e analisi *case history* locali
- Consulenza strategica e tecnica, dalla progettazione alla realizzazione
- Assistenza e consulenza per *format* e progetti diversi
- Tutor qualificati e riconosciuti a livello nazionale
- Trimestrale dal 2019





60+ amministratori e tecnici da 15 comuni



CReIAMO PA

Per un cambiamento sostenibile

Bicipolitana *leggera*: Itinerari ciclabili in sola segnaletica



Integrati nelle linee di PUMS

Orientano il cittadino alla mobilità attiva

Generano contatti, dibattito e coinvolgimento

Provvisori o permanenti, budget limitato



LineaMi della Bicipolitana

Dergano – Angilberto – Dergano

Milano Bike City 2018

14 “fermate”

92 “direzionali”

120 cartelli

8,6 Km.

Ca. 45% ciclabile

40' percorrenza

QR Code

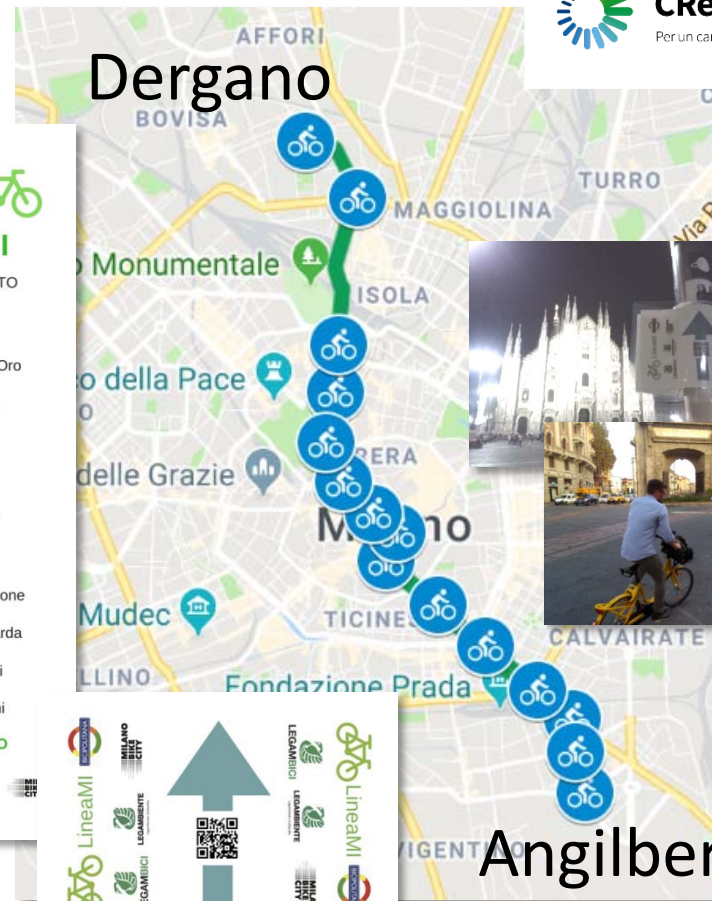

Angilberto

Bicipolitana *CicloPop*: Sedi ciclabili provvisorie

Migliorano il senso di comunità
Evidenziano l'alternativa di mobilità già esistente
Generano contatti, dibattito e coinvolgimento
Budget limitato, dimensione scalabile
In sintonia con altri progetti





SPOGLIATOIO DONNE

B2W!



Per PA e aziende

Moduli formativi e attività
progressive e scalabili



CReIAMO PA

Per un cambiamento sostenibile

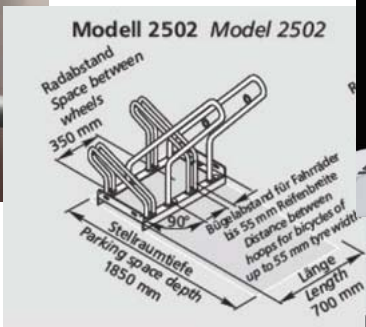
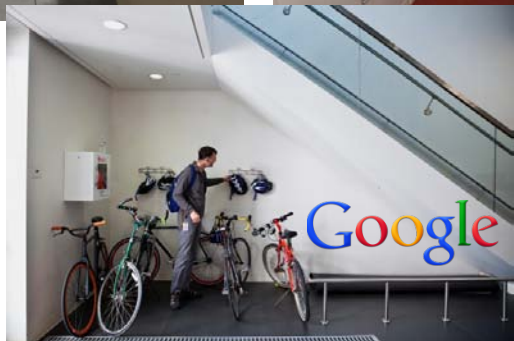



CReiAMO PA
Per un cambiamento sostenibile

Tactical urbanism:
Interventi urbanistici diffusi

Sostengono le iniziative a favore della ciclabilità
Restituiscono lo spazio pubblico alle persone
Rivitalizzano le attività commerciali
Generano benessere e aumentano la sicurezza

#piazzeaperte
#Milano

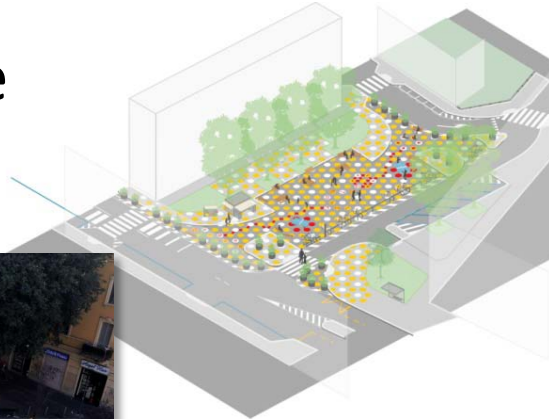

Tactical urbanism:
Interventi urbanistici diffusi

Mission

NACTO's mission is to build cities as places for people, with safe, sustainable, accessible and equitable transportation choices that support a strong economy and vibrant quality of life.

About NACTO >

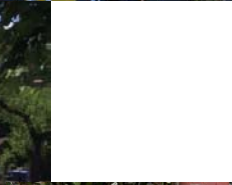



CReIAMO PA

Per un cambiamento sostenibile

#BRUSSELSFORPEOPLE



CRiAMO PA

Per un cambiamento sostenibile

BRUSSELS TODAY



**1,2 MILLIONS
INHABITANTS**



350.000 COMMUTERS



50% BY CAR



**INTERNATIONAL ><
PROVINCIAL**



CAPITAL CITY



**ING = ESSENTIAL IN
Y LIFE**

IT HUMANIZES A CITY

IT BRINGS LOVE

IT LIBERATES SPACE

IT'S CHEAPER

IT'S SEXIER



CReIAMO PA
Per un cambiamento sostenibile



CReiAMO PA

Per un cambiamento sostenibile





CREIAMO PA

Per un cambiamento sostenibile



#BRUSSELSFORPEOPLE



#BRUSSELSFORPEOPLE

PEDESTRIAN ZONE



CReIAMO PA

Per un cambiamento sostenibile

**TAKE THE BIKE
SUSTAINABLE IN STREETS**

DO AS YOU PREACH





CReIAMO PA

Per un cambiamento sostenibile

CONCLUSION

COME BACK TO FUTURE

CAR FADE

**BIKE & PUBLIC TRANSPORT
REVIVAL**





CREIAMO PA

Per un cambiamento sostenibile

CONCLUSION

COME PER IL FUTURO

CARTE

BIKE PUBLIC TRANSPORT
REVIV

€€€

, €€€ ! !





CReIAMO PA

Per un cambiamento sostenibile

Il Messaggero.it

Nomentana, la cicloabile che cancella 160 posti auto: proteste dei residenti

ROMA > CRONACA
Domenica 28 Gennaio 2018 di Camilla Mozzi



Il progetto è stato annunciato e le critiche dei residenti. Le strisce di marciapiede vengono cancellate per far posto alla nuova cicloabile. Le polemiche si accaniscono sui social network. I manifestanti chiedono che il progetto venga cancellato.

CREMONA
Via Mantova, nuova cicloabile: subito proteste e polemiche

Le critiche si sono moltiplicate sui social network. I manifestanti chiedono che il progetto venga cancellato. Le polemiche si accaniscono sui social network. I manifestanti chiedono che il progetto venga cancellato.

Pia a via Val d'Aosta-Valdarno) che però genera adesso malumori tra i residenti. «Dove andremo a parcheggiare delle tante residenti, Letizia Magistri, che ha già inviato il sindaco Raggi. Il progetto infatti prevede la cancellazione di 160 posti auto riservati ai cittadini che vivono sulla Nomentana».

LA PISTA CICLABILE NON PUO' PIU' VENDERE". LA PROTESTA DEI COMMERCianti DI ROMA TUSCOLANA

7 dicembre 2018

La riunione esterna della giunta capitolina che si è tenuta oggi a Roma, in via Tuscolana, alla quale hanno partecipato i commercianti della zona, ha deciso di protestare contro la nuova pista ciclabile in costruzione lungo una delle zone più

LETTIZIA DI PARMA

IL MIO CO... EVENTI FILM... TORANTI... IL PARMA... ZAREPOR... ELEZIONI 2019

Video

La nuova cicloabile e le proteste

RUSSIA
Ubricato te

LA STAMPA BIELLA

Avanza in centro la nuova pista ciclabile, ma sui social fioccano le proteste dei cittadini



CReIAMO PA

Per un cambiamento sostenibile

Grazie.

@Legambici

